

# Nema 23

2 phase 1.8° step angle  
 hybrid stepping motor

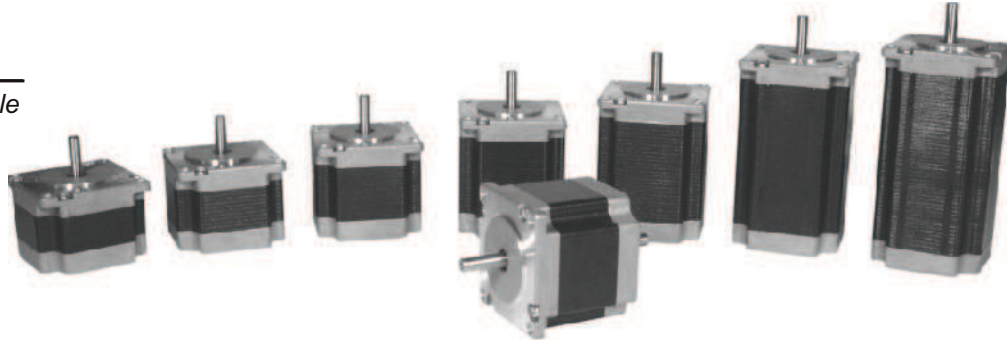

Specifications:

Model	Holding Torque (Nm)	Phase current (A)	Rotor Inertia (g/cm <sup>2</sup> )	Motor Length L max (mm)	Detent Torque (Nm)	Phase Resistance (ohm)	Phase Inductance (mH)	Lead Wire (No)	Motor Weight (Kg)	Note
<b>M1233011</b>	0.55	0.62	150	41	0.025	13	34	4	0.47	
<b>M1233012</b>	0.55	2.0	150	41	0.025	1.2	3.20	4	0.47	
<b>M1233021</b>	0.80	0.62	190	45	0.028	12	29	4	0.52	
<b>M1233022</b>	0.80	2.5	190	45	0.028	1.0	2.2	4	0.52	
<b>M1233031</b>	1.00	0.62	190	51	0.028	13.4	33	4	0.62	
<b>M1233032</b>	1.10	2.5	190	51	0.028	1.15	3.3	4	0.62	
<b>M1233041</b>	1.10	4.2	280	56	0.035	0.4	1.2	4	0.68	
<b>M1233051</b>	1.40	3.0	380	64	0.05	0.8	2.4	4	0.85	8 mm shaft available
<b>M1233061</b>	1.80	3.0	440	76	0.06	1.0	3.54	4	1.05	
<b>M1233062</b>	1.80	4.2	440	76	0.06	0.55	1.8	4	1.05	
<b>M1233064</b>	1.80	6.0	440	76	0.06	0.3	1	4	1.05	
<b>M1233070</b>	3.00	4.2	680	100	0.1	0.8	3.0	4	1.5	
<b>M1233071</b>	3.00	6.0	680	100	0.1	0.4	1.5	4	1.5	
<b>M1233081</b>	3.40	6.0	800	112	0.12	0.44	1.9	4	1.7	

Double shaft and custom windings available

Mechanical Dimensions:

Unit: mm

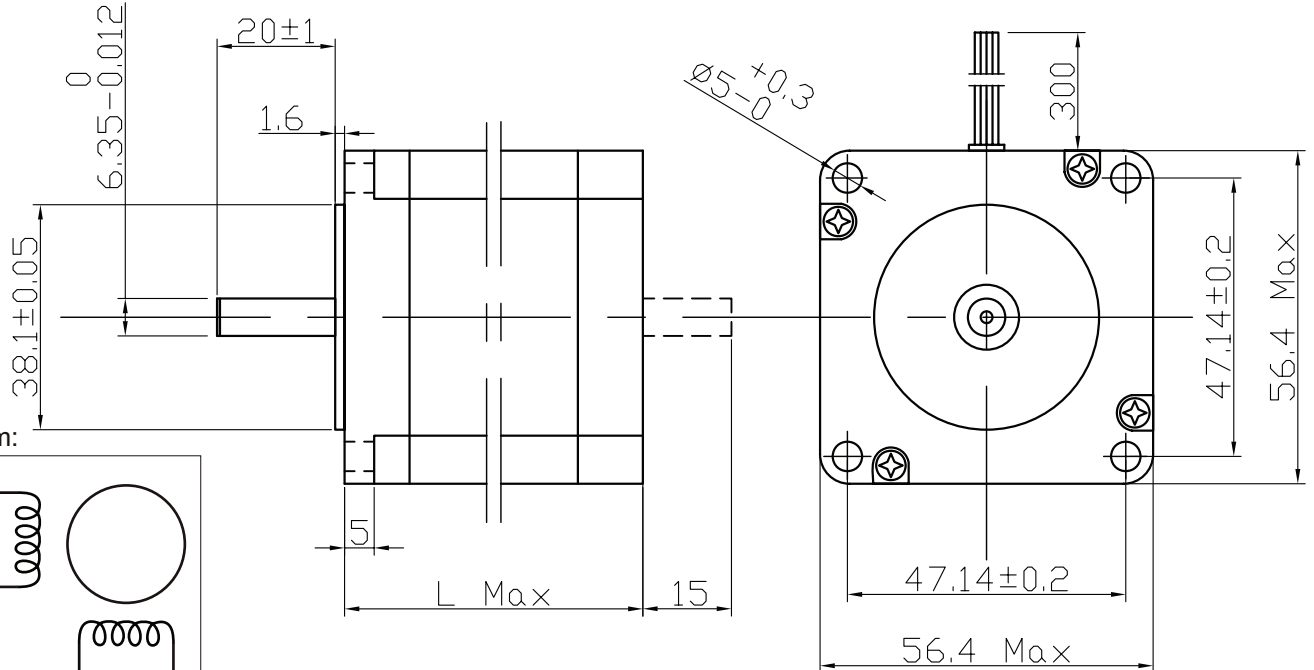

Wiring Diagram:

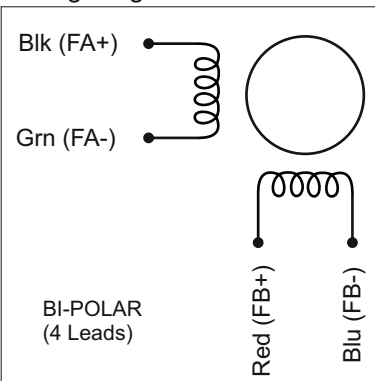

M1233011

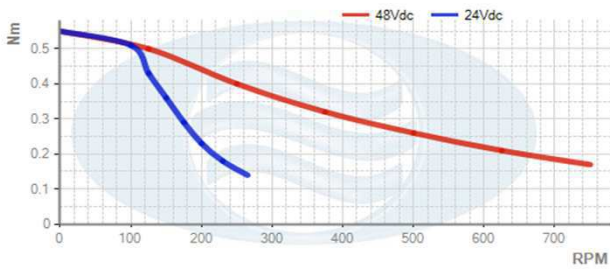

M1233012

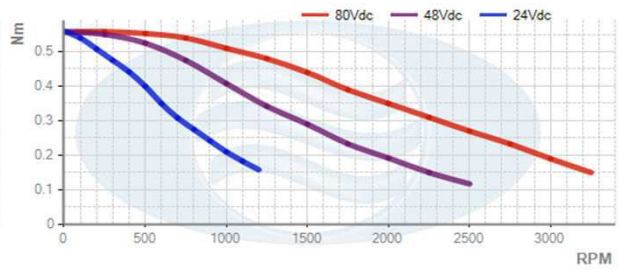

M1233021

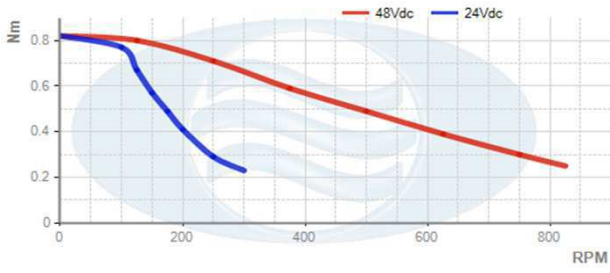

M1233022

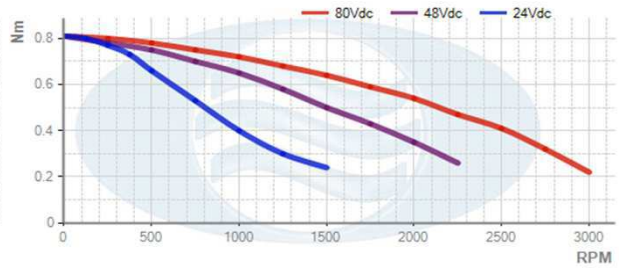

M1233031

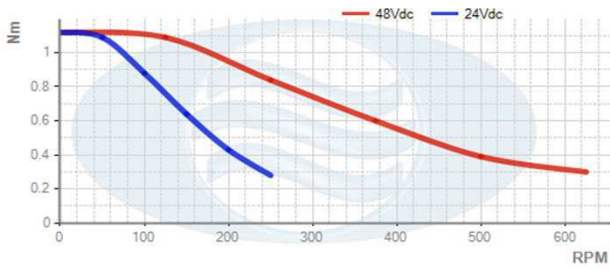

M1233032

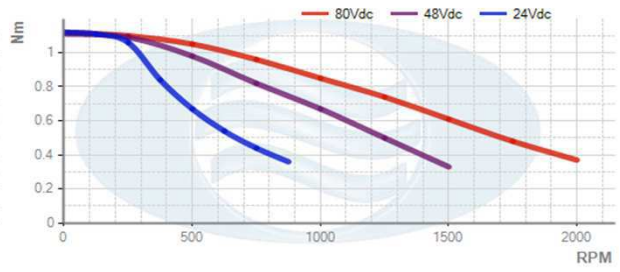

M1233041

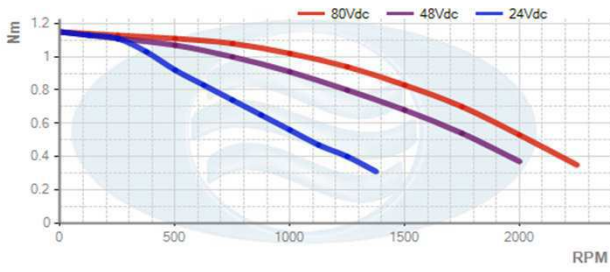

M1233051

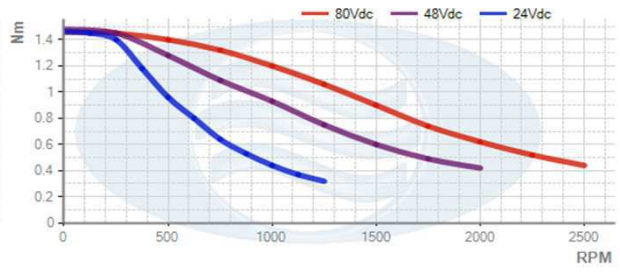

M1233061

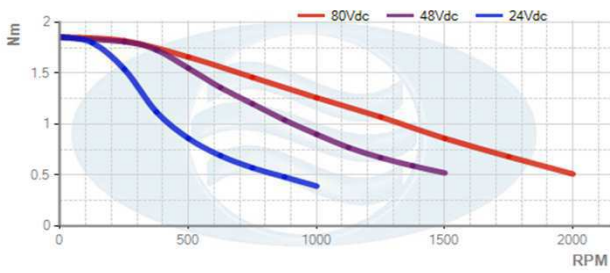

M1233062

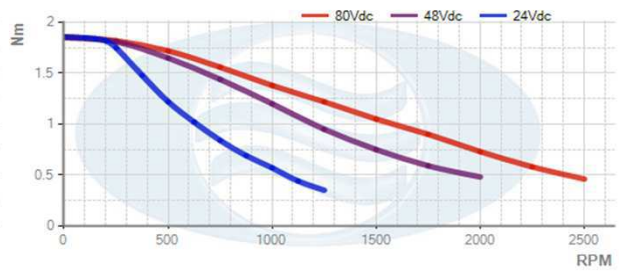

M1233064

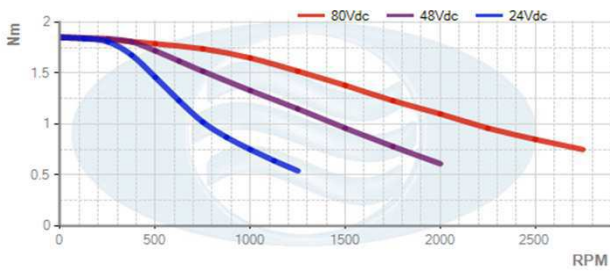

M1233070

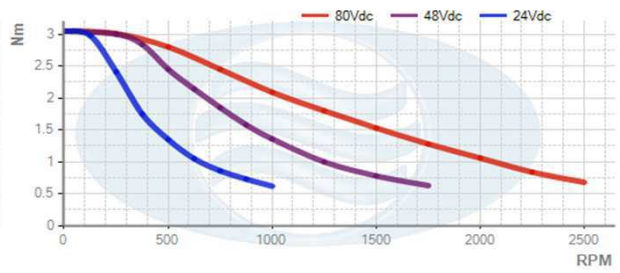

M1233071

